

QSRF 875 (GC8)

QUASAR Flooded Carbon Nano Battery

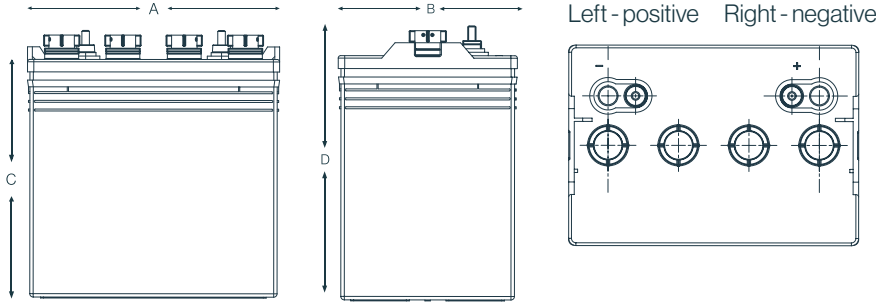

Electrical Specifications

C5 Capacity	145Ah
C20 Capacity	170Ah
Capacity Minutes @25 Amps	294
Capacity Minutes @75 Amps	116
Voltage	8V
80% DOD Voltage Cutoff	7.5V
Self Discharge	Less than 3% per month (20°C/68°F)
Charge Temperature	Min: -10°C (14°F) / Max: 50°C (122°F)
Discharge Temperature**	Min: -40°C (-40°F) / Max: 50°C (122°F)
Storage	Min: -20°C (-4°F) / Max: 60°C (140°F)

Mechanical Specifications

Industry Reference	GC8	
Length (A)	10.2in	260 mm
Width (B)	7.1in	180 mm
Height over lid (C)	9.7in	247 mm
Height over stud (D)	10.9in	277 mm
Weight	63.9 lbs	29 kgs
Terminal (Opt'l)	UTL	
Cell(s)	4	
Electrolyte	Flooded	
Terminal Torque Nm	11-12Nm	

NOTE: There is a tolerance of +/-2%.

Capacity vs Temperature

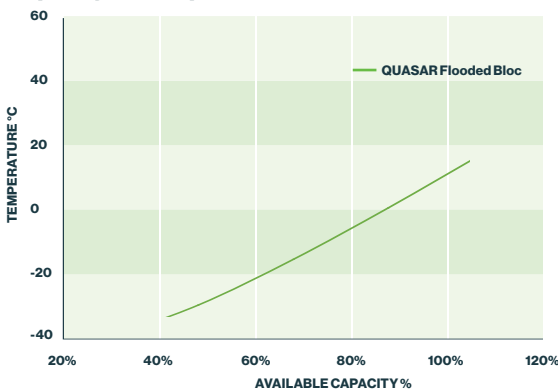

Features

- Ultra energy efficient due to low resistance
- Increased cycle life due to Carbon Nano Tube Technology
- Suitable for opportunity charging
- Cost savings due to increased efficiency
- Up to 2 x faster recharge
- Allows for opportunity charging to give you those extra running times when required
- Suitable for extreme temperature variants

Applications

- Golf carts, including electric vehicles
- Access Work Platform (AWP)
- Cleaning Machines
- Maritime
- Wheelchairs
- Solar & Renewable Energy
- Traffic Systems
- Caravans / Motorhomes RV's
- Home Invertor

UTL Positive & Negative

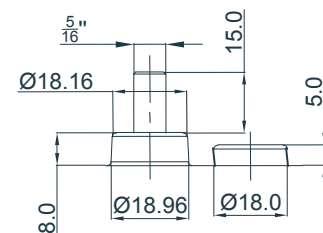

Compliant with: IEC 60254

Designed in compliance with applicable BCI, DIN, BS and IEC standards. Tested in compliance to BCI and IEC standards.

Charging profile

IUI Charging $I_1 = \text{min. } 12\% C_5 \text{ max. } 40\% C_5$
 $U = 2.45 \text{ V per cell}$
 $I_2 = 6\% C_5 \text{ for max. } 4 \text{ hours}$

Charging instructions

Charging Voltage Settings 77°F / @ 25°C				
System Voltage	Per Cell	8V	24V	48V
Bulk Charge	2.47	9.88	29.64	59.28
Float Voltage	2.25	9.00	27.00	54.00
Equalize Voltage	2.70	10.8	32.40	64.80

Charging temperatures

ADD	SUBTRACT
0.005Vpc for every 1°C below 25°C	0.005Vpc for every 1°C above 25°C
0.0028Vpc for every 1°F below 77°F	0.0028Vpc for every 1°F above 77°F

State of Charge Measure of Open - Circuit Voltage

% of SoC	Sp.Gravity	OCV	
		Cell	8V
100	1.285	2.125	8.50
90	1.265	2.105	8.42
80	1.246	2.086	8.34
70	1.227	2.067	8.27
60	1.207	2.047	8.19
50	1.188	2.028	8.11
40	1.169	2.009	8.04
30	1.150	1.990	7.96
20	1.130	1.970	7.88
10	1.111	1.951	7.80
0	1.092	1.932	7.73